



XWL-SS 252 Series



不锈钢泵头



铝合金连杆

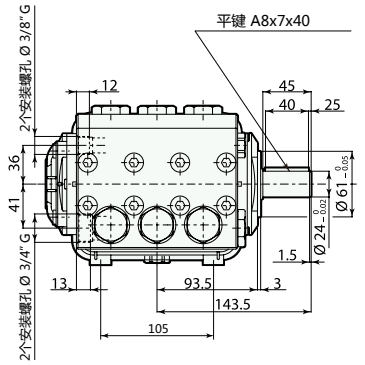
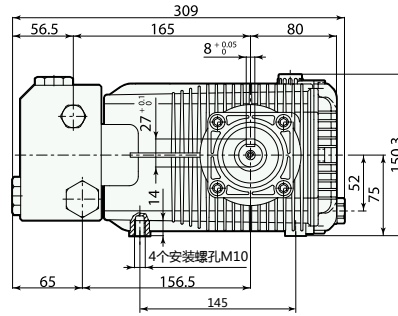

型号	流量		压力		电机功率		重量 kg	转速 rpm	温控阀 TRV	进水口	出水口	编号
	l/min	gpm	bar	psi	hp	kw						
XWL-SS 1450 转 N 轴 24mm 实心轴												
XWL-SS 26.12 N	26	6.87	120	1800	9.0	6.5	18.0	1450	无	3/4"GF	3/8"GF	TBA
XWL-SS 30.12 N	30	7.92	120	1800	10.0	7.0	18.0	1450	无	3/4"GF	3/8"GF	TBA
XWL-SS 42.15 N	42	11.09	150	2200	16.5	12.1	18.0	1450	无	3/4"GF	3/8"GF	21704
XWL-SS 50.15 N	50	13.20	150	2200	20.0	15.0	18.0	1450	无	3/4"GF	3/8"GF	24105

- 所有与泵送液体接触的机械零部件均由不锈钢316L材质制造。