

UN003285-DU

## PART KITS / 配套零件

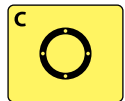
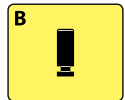
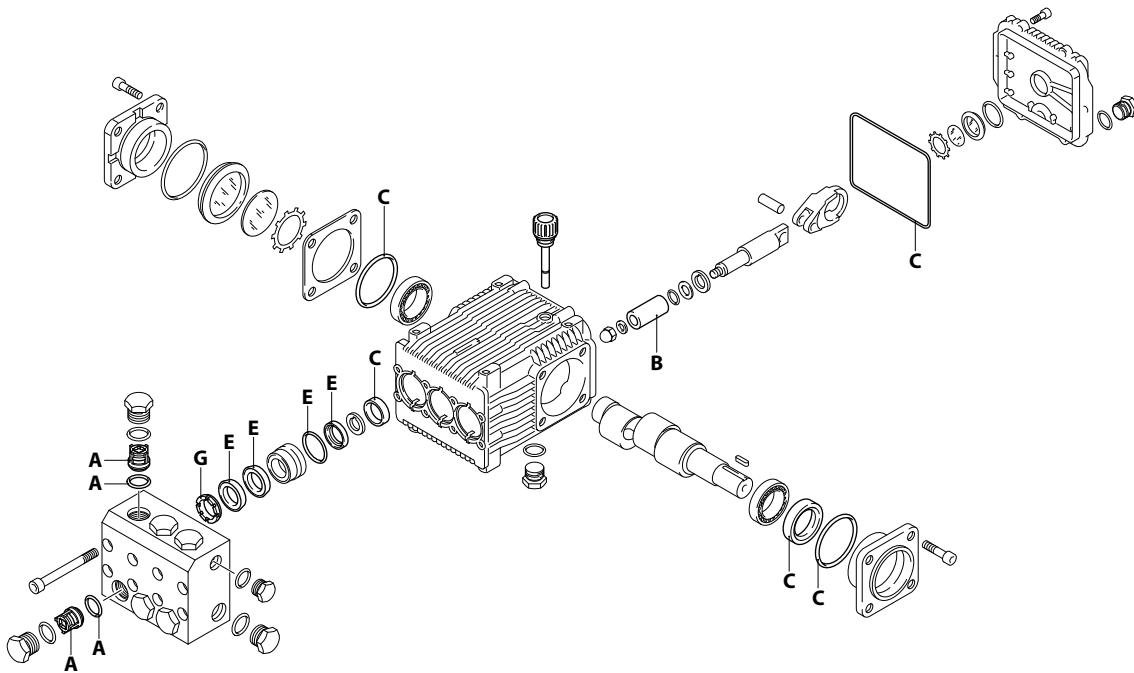

UN003286-DU

# 234 Series

RK-SS 1450 rpm N version ø 24 mm

11.11 13.17 15.15 21.15



Pos. 序号	Cod. 编号	Description	描述	Qt 数量	Note 备注	Pos. 序号	Cod. 编号	Description	描述	Qt 数量	Note 备注
1	960161	O-ring	Ø 17,86x2,62	6		43	2340350	Plug	3/8" G	2	C=20Nm
2	2340030	Plug		6	☉C=50Nm	46	2340050	Plug	3/8" NPT	1	
3	2349050	Complete valve		6		48	2340350	Plug	3/8" G	1	
4	880831	O-ring	Ø 15,54x2,62	6		49	2340040	Plug	3/8" NPT	1	
11	960110	Ring	appoggio Ø18	3	○ □ ■	50	2340360	Plug	1/2" G	1	
	840320	Ring	appoggio Ø22	3	✘	51	2340020	Head		1	✘ NPT
12	880321	Gasket	Ø 18	3	○ □ ■ ✘	52	2340370	Head		1	○ □ ■ GAS
	840331	Gasket	Ø 22	3	✘ ✘	53	2340340	Head		1	✘ GAS
13	2340140	Piston guide	Ø 18	3	○ □ ■	54	1383440	Screw	TCEI M8x70	8	C=24,5Nm
	2340420	Piston guide	Ø 22	3	✘	55	2340190	Plate		3	
14	961241	O-ring	Ø 31,47x1,78	3		56	1383140	Bearing		1	
15	880331	Gasket	Ø 18	3	○ □ ■ ✘	57	2349202	Head assembly		1	✘ NPT
	2340410	Gasket	Ø 22	3	✘ ✘	58	2349203	Head assembly		1	○ □ ■ GAS
16	1383130	Ring	tenuta	3		59	2349205	Head assembly		1	✘ GAS
17	2340240	Screw	TCEI M8x16	8	C=20Nm / Inox	60	2340310	Ring	antiestrusione	3	○ □ ■
18	2349011	Cover		1		61	2340330	Ring	antiestrusione	3	✘
19	640030	O-ring	Ø 59,99x2,62	2		62	180102	O-ring	Ø 17,5x2	1	
20	2280340	Bearing		1	○ □	63	740291	O-ring	Ø 14x1,78	1	
21	2340260	Pump body		1	✘	64	1260250	Level gauge		1	
22	880130	Plug		1		65	1260430	Ring		1	
23	2340060	Nut		3	C=23Nm	66	1780690	Plate		1	
24	2340200	Washer		3		67	1140450	O-ring	Ø 20,24x2,62	1	
25	1383230	Piston	Ø 18	3	○ □ ■	68	1080550	Ring	antiestrusione	3	
	1383340	Piston	Ø 22	3	✘	69	100410	O-ring	Ø 34,6x2,62	1	
26	2340110	Spacer	Ø 18	3	○ □ ■	70	1941270	Level gauge		1	
	2340430	Spacer	Ø 22	3	✘	71	1941260	Plate		1	
27	480482	O-ring	Ø 4,48x1,78	3		72	1941290	Ring		1	
28	1383240	Piston	di guida	3							
29	1380060	Pin		3							
30	1383020	Connecting-rod	bronzo	3							
34	1780510	O-ring	Ø 106x3	1							
35	2349010	Cover	completo	1							
36	2340250	Screw	TCEI M6x14	6							
37	1380520	Key		1							
38	180340	Ring	tenuta	1	(a)						
39	2280100	Shaft	marcato 5	1	○						
	2280080	Shaft	marcato 3	1	□						
	2280060	Shaft	marcato 1	1	■						
	2280070	Shaft	marcato 2	1	✘						
40	1380130	Shim 0.20 mm		1-3							
41	2340280	Support	cuscinetto aperto	1							
42	740290	O-ring	Ø 14x1,78	2							

## PART KITS - 配套零件

A=KIT 2514 valves 单向阀		B=KIT 2515 ø 18 pistons 柱塞		B=KIT 2526 ø 22 pistons 柱塞		C=KIT 2528 oil seals 油封	
Pos. 序号	Q.ty 数量	Pos. 序号	Q.ty 数量	Pos. 序号	Q.ty 数量	Pos. 序号	Q.ty 数量
3	6	25	3	25	3	16	3
4	6					19	2
						34	1
						38	1

E=KIT 2516 ø 18 water seals 水封		E=KIT 2527 ø 22 water seals 水封		G=KIT 1829 ø 18 support rings 支撑环		G=KIT 1816 ø 22 support rings 支撑环	
Pos. 序号	Q.ty 数量	Pos. 序号	Q.ty 数量	Pos. 序号	Q.ty 数量	Pos. 序号	Q.ty 数量
12	3	12	3	11	3	11	3
14	3	14	3				
15	3	15	3				
79	3	79	3				

## SIMBOLOGIA - 标记

○ For / 用于 RK-SS 11.11 N □ For / 用于 RK-SS 13.17 N ■ For / 用于 RK-SS 15.15 N ✘ For / 用于 RK-SS 21.15 N

C Tightening torque tolerance 0±10% / 拧紧力矩公差 0±10%  
 ☉ Screw with Loxeal 55-14 / 用 Loxeal 55-14 螺丝  
 ✘ Lubricate with grease Molykote PGS4 on the INNER diameter only / 仅在口径内侧用 Molykote PGS4 润滑  
 (a) Fit the seal with tool code nr. 2281010 / 使用工具 nr. 2281010 进行密封  
 GAS Gas thread / Gas 螺纹  
 NPT NPT thread / NPT 螺纹

Oil - 机油	
Type / 类型	Quantity / 数量
SAE 75W90	0,415 Kg