



# 液压驱动



铜泵头



铝合金连杆

## 194 Series

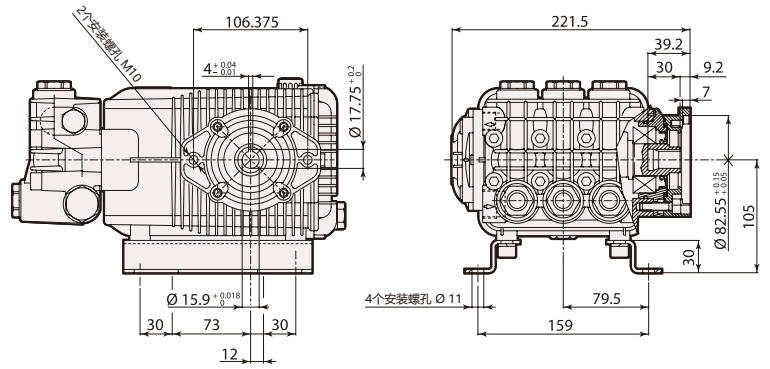

型号	流量		压力		功率		重量	转速	温控阀	进水口	出水口	编号
	l/min	gpm	bar	psi	hp	kw	kg	rpm	TRV			
<b>XW + F38 法兰适用于液压驱动</b>												
XW 30.15+F38	30	7.92	150	2200	12.0	9.0	16.5	1450	无	3/4"GF	3/8"GF	<b>22318</b>
XW 50.15+F38	50	13.2	150	2200	12.0	9.0	16.5	1450	无	3/4"GF	3/8"GF	<b>27630</b>