

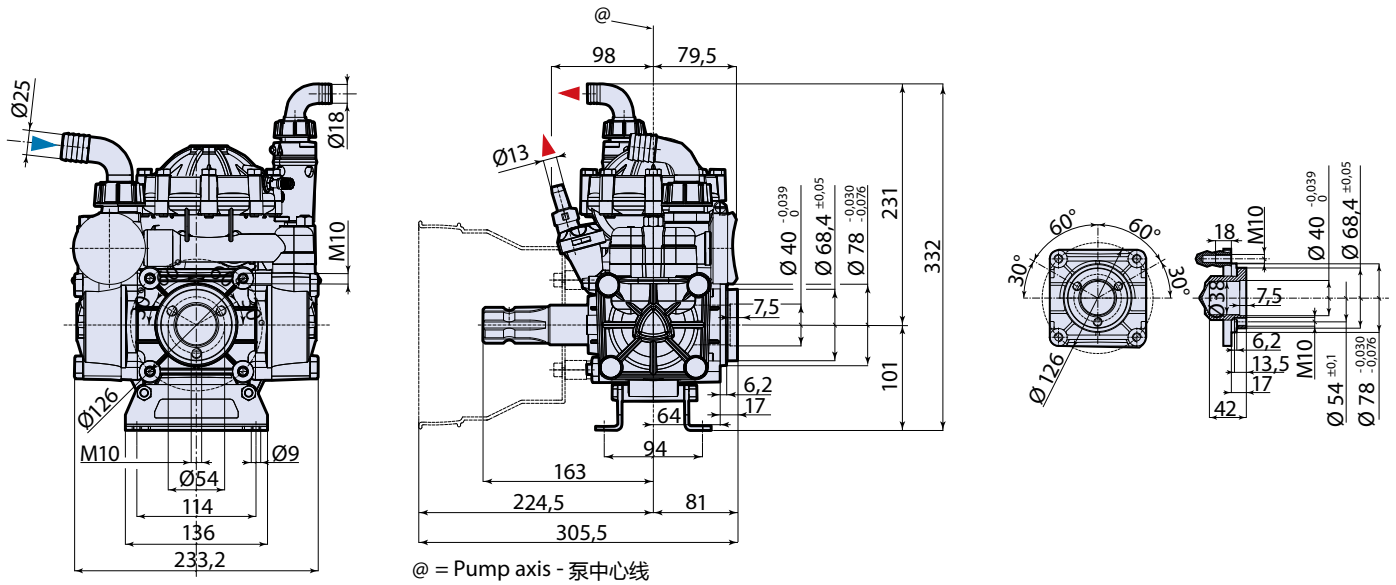

AR 30

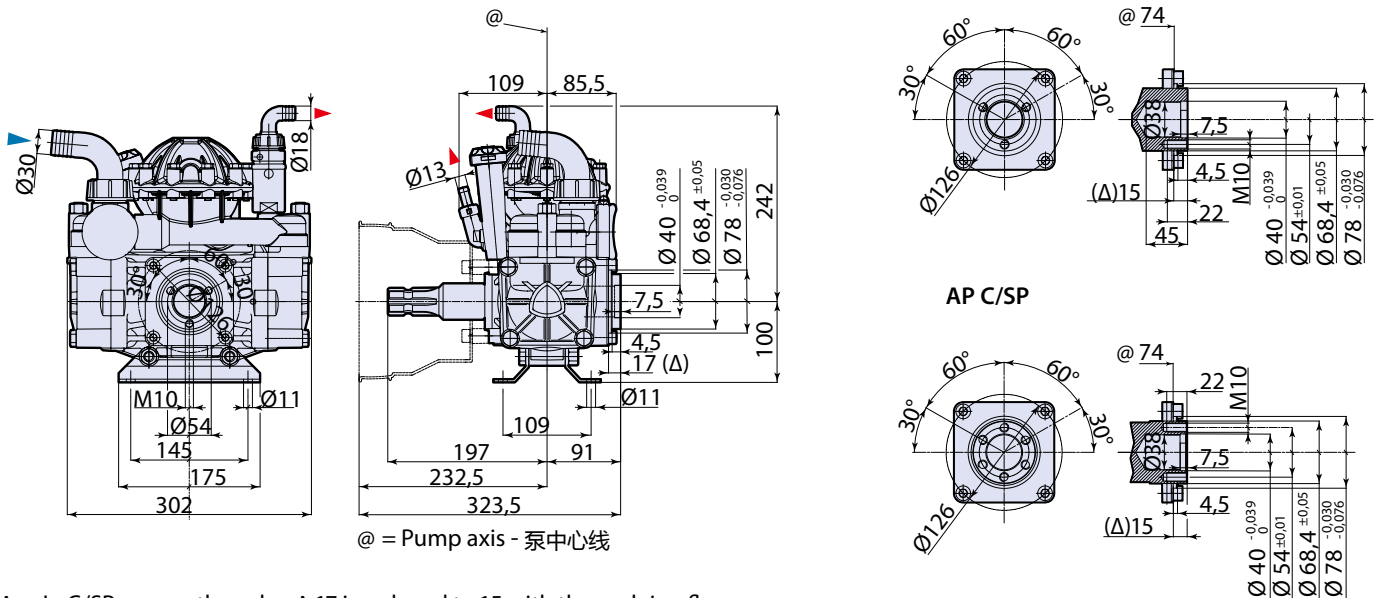

AR 50



- Δ In C/SP pumps the value Δ 17 is reduced to 15 with the seal ring flange mounted on the pump body. N.B. remove the seal ring flange code 1400140 before fitting the reduction gear to the pump.
- Δ 在C/SP泵中，安装在泵体上的密封环法兰的数值Δ17改成了15。注意：在泵安装减速箱之前，先移除编号1400140密封环法兰。