

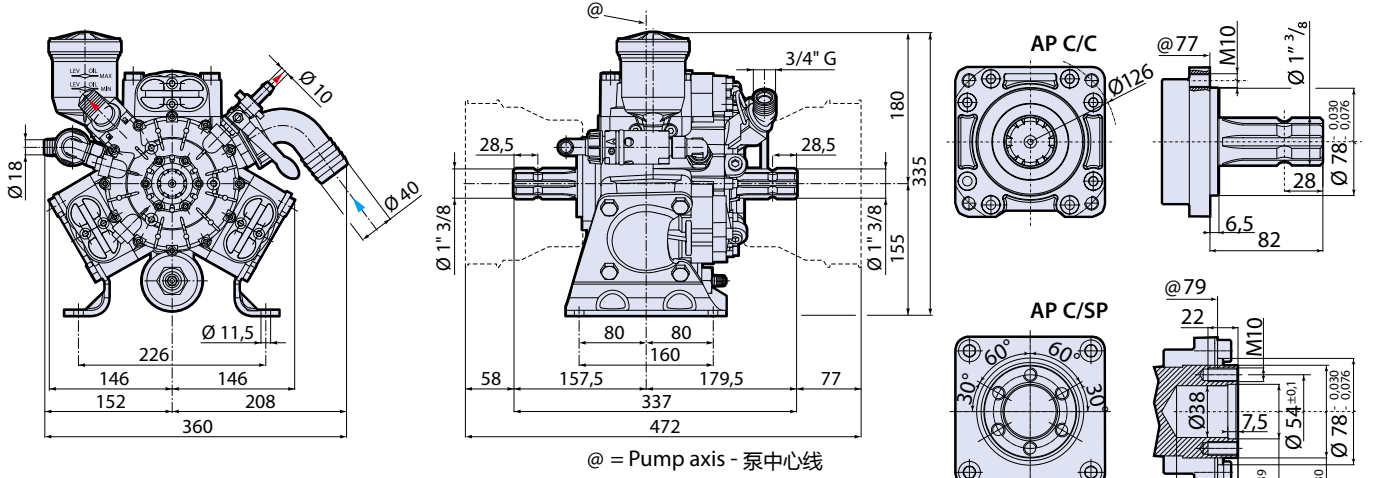

# AR 713 - AR 813



- Δ In C/SP pumps the value Δ 17 is reduced to 15 with the seal ring flange mounted on the pump body. N.B. remove the seal ring flange code 1400140 before fitting the reduction gear to the pump.
- Δ 在C/SP泵中, 安装在泵体上的密封环法兰的数值Δ17改成了15。注意: 在泵安装减速箱之前, 先移除编号1400140密封环法兰。



# AR 1064

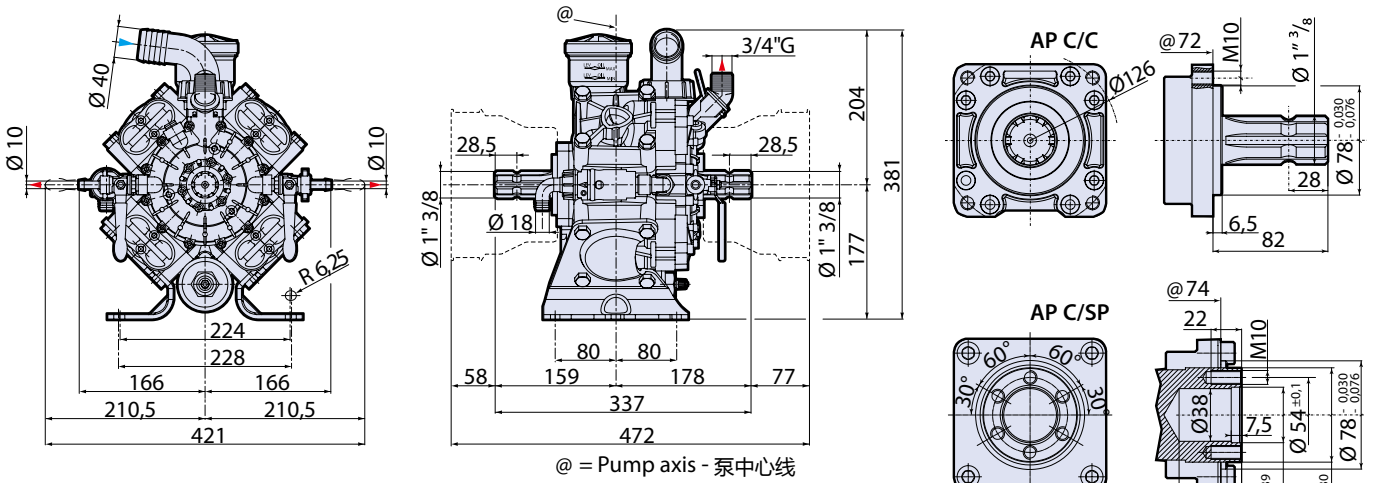

- Δ In C/SP pumps the value Δ 17 is reduced to 15 with the seal ring flange mounted on the pump body. N.B. remove the seal ring flange code 1400140 before fitting the reduction gear to the pump.
- Δ 在C/SP泵中, 安装在泵体上的密封环法兰的数值Δ17改成了15。注意: 在泵安装减速箱之前, 先移除编号1400140密封环法兰。



# AR 903 - AR 1053 - AR 1203

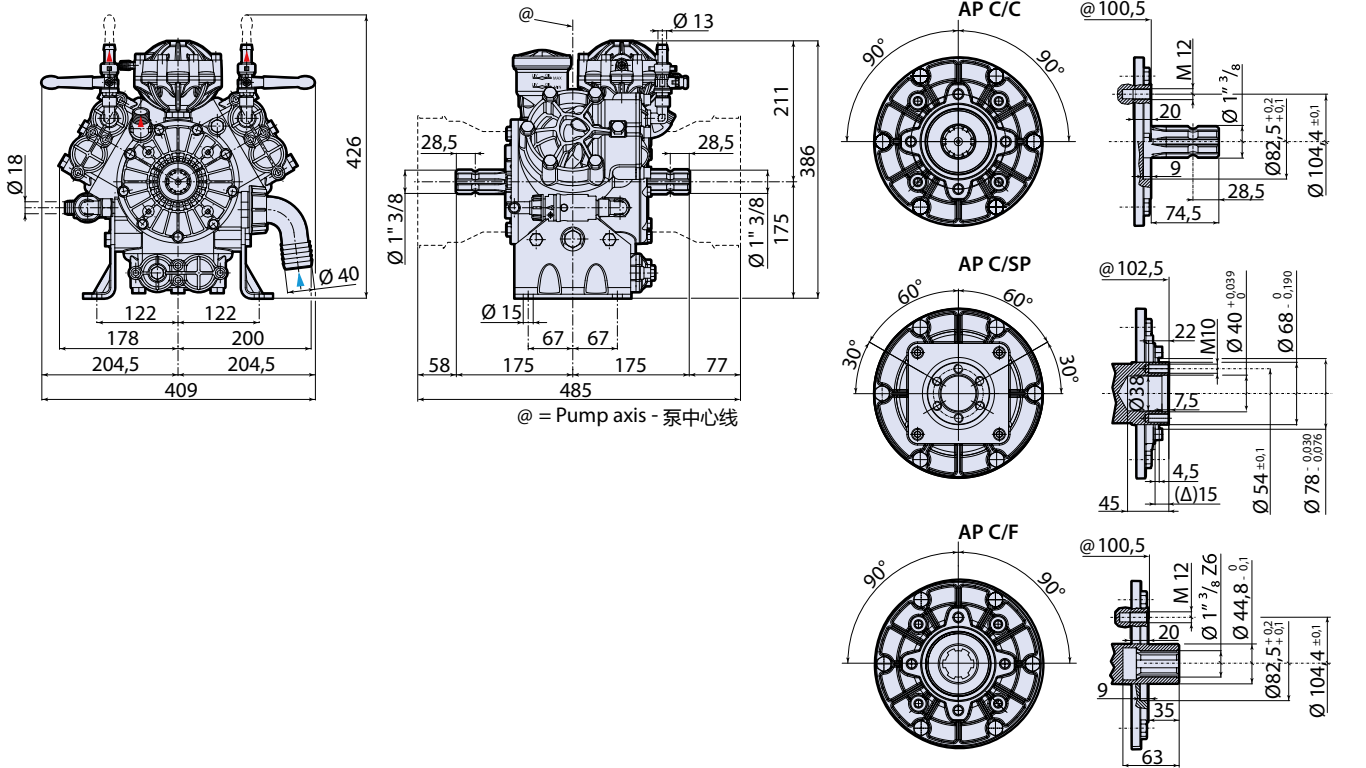

# AR 1604

